

SUBMITTAL DATA: MSZ-D30NA-8 & MUZ-D30NA-1
 30,000 BTU/H WALL-MOUNTED HEAT-PUMP SYSTEM

Job Name:

System Reference:

Date:



Indoor Unit: MSZ-D30NA-8



Wireless Remote Controller



Outdoor Unit: MUZ-D30NA-1

GENERAL FEATURES

- Catechin and anti-allergy enzyme filters for high air-purification capabilities
- Updated sleek, compact indoor unit design
- Remote-controlled wide airflow enables ideal horizontal air distribution
- Self-check function—onboard diagnostics
- Advanced microprocessor control
- Auto restart following a power outage
- Hand-held Wireless Remote Controller
- Anti-allergy Enzyme Filter
- Limited warranty: five years parts and seven years compressors

ACCESSORIES
Outdoor Unit

- Drain Socket Assembly (MAC-811DS)

Indoor Unit

- Condensate Pump (230V; SI3100-230)

Controller Options

- Wireless Wall-mounted Remote Controller Kit (MHK1)*
 - Portable Central Controller (MCCH1)*
 - Outdoor Air Sensor (MOS1)*
 - Wired Wall-mounted Controller (PAR-31MAA requires MAC-333IF)*
 - Simple MA Remote Controller (PAC-YT53CRAU requires MAC-333IF)*
- *See Submittal for information on each option.
- System Control Interface (MAC-333IF)



DIMENSIONS: MSZ-D30NA-8 & MUZ-D30NA-1

MSZ-D30NA-8

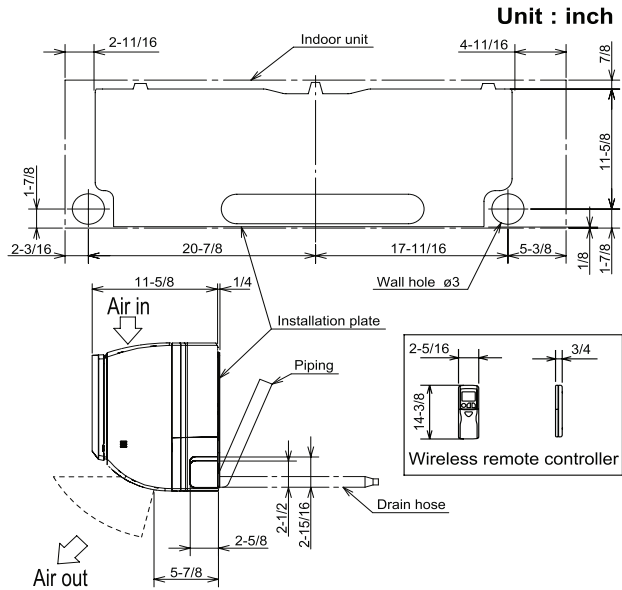
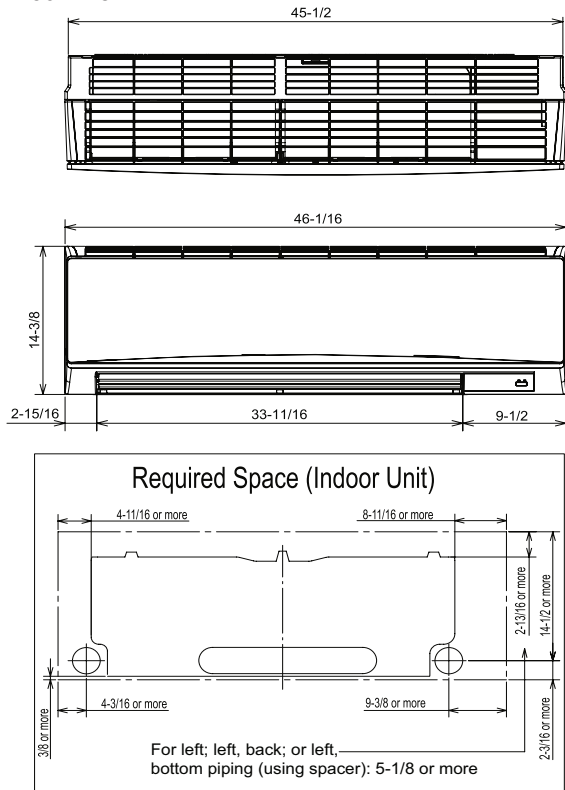

	Piping	Insulation
Liquid line	$\phi 3/8$ 19-11/16 (Flared connection $\phi 3/8$)	$\phi 1-1/4$ O.D. $\phi 9/16$ I.D.
Gas line	$\phi 5/8$ 16-7/8 (Joint connection $\phi 5/8$)	$\phi 1-15/16$ O.D. $\phi 1-1/4$ I.D.
Joint	$\phi 5/8$ (Flared connection $\phi 5/8$)	$\phi 1-15/16$ O.D. $\phi 1-1/4$ I.D.
Drain hose	Insulation $\phi 1-1/8$ Connected part $\phi 9/16$ O.D.	

MUZ-D30NA-1

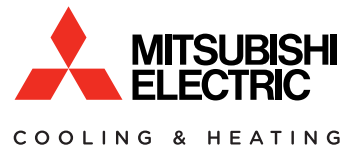
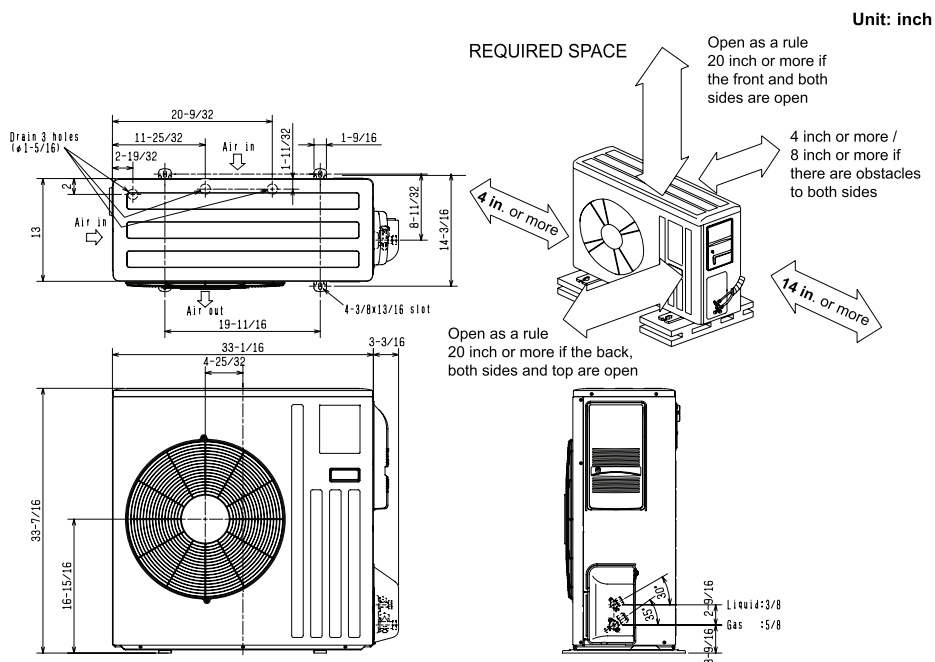

1340 Satellite Boulevard
Suwanee, GA 30024
Tele: 678-376-2900 • Fax: 800-889-9904
Toll Free: 800-433-4822
www.mehvac.com